

PROYECTO DE REPARCELACION UA - 7 EL ALBUJON

FINCA Nº 5 : CEDULA URBANISTICA : Vu1/5

PARCELA : MANZANA 5

ADJUDICADA	%	M2
------------	---	----

VICOPRO S.A	100	70
-------------	-----	----

USOS PERMITIDOS : RESIDENCIAL

LINDEROS :

Norte y Oeste: Núcleo El Albuji3n y Ejidos del Caserio de los Arroyos

Este : Calle Garcia

Sur: Calle Lanuza

CONDICIONES DE EDIFICABILIDAD :

ALTURA MAXIMA : 2 Plantas y 7 m

EDIFICABILIDAD: 49 (0.7 m²/m² parcela neta)

Nº DE VIVIENDAS: 0

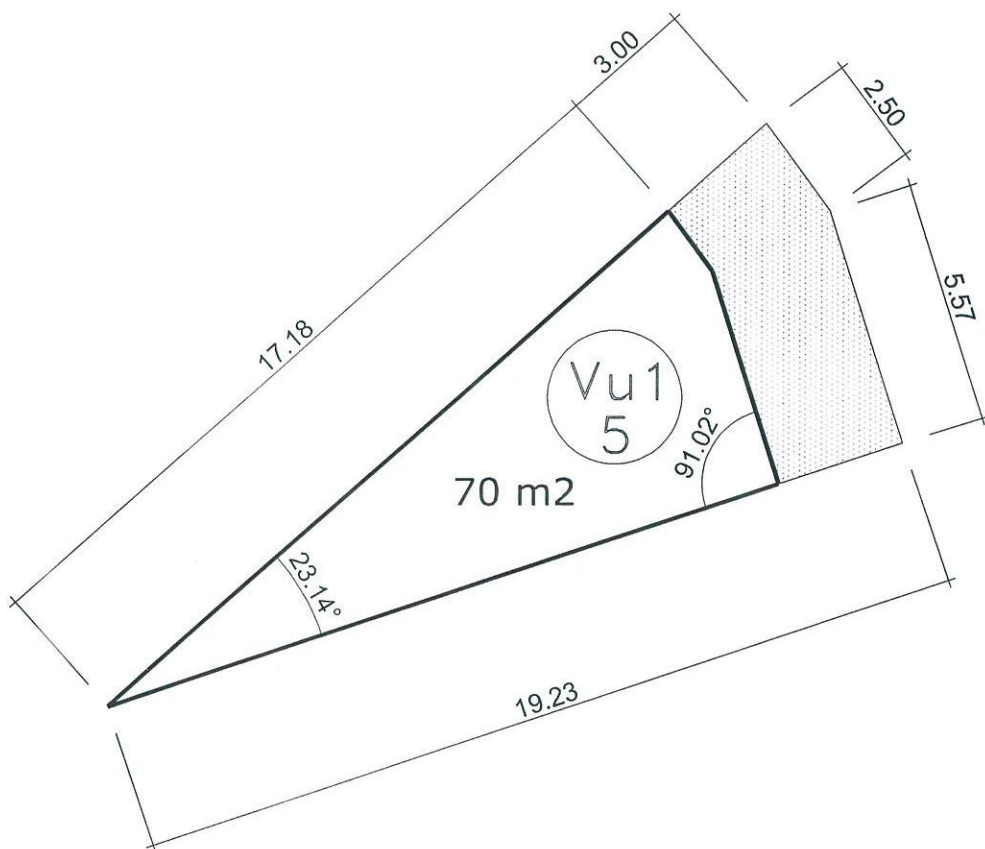

	JARDIN PRIVADO SUP. 19.00 m ²
	SUP. EDIFICABLE SUP. 51.00 m ²
	SUP. TOTAL SUP. 70.00 m ²

Afecta al pago de 1.496,53 Euros por Obras de Urbanizaci3n
Equivalente al 0.95 % del total.